

**BiPotentiostat/BiGalvanostat with built-in EIS model CS2350M** has two sets of built-in independent potentiostat /galvanostat. Experiments can be conducted simultaneously in each channel. Besides this, the two channels can jointly complete experiment of two-working electrode system such as RRDE and Hydrogen diffusion. CS2350M bipotentiostat is the real double-channel potentiostat. It uses Ethernet connection. The customer can choose to use only one channel or both channels during experiment. EIS module is included in each channel.



## Application

- (1) Electrosynthesis, electrodeposition (electroplating), anodic oxidation, electrolysis
- (2) Oxygen reduction reaction (ORR), oxygen evolution reaction (OER), Hydrogen evolution reaction (HER), carbon dioxide reduction.
- (3) Energy and materials (Li-ion battery, solar cell, fuel cell, supercapacitor), advanced function materials, and sensor.
- (4) Corrosion behavior of metals, and anti-corrosion evaluation
- (5) Fast evaluation of inhibitor, water quality stabilizer, coating, and cathodic protection efficiency.

## Rotating Ring-Disk Electrode (RRDE)

Oxidation/reduction reaction (ORR) study: while measuring the polarization curve of disk electrode in the main channel, apply a constant polarization potential on the ring electrode, and thus detect the intermediate products on the disk electrode. RRDE test becomes the typical method for ORR study. CS2150 can be connected to any RRDE equipment.

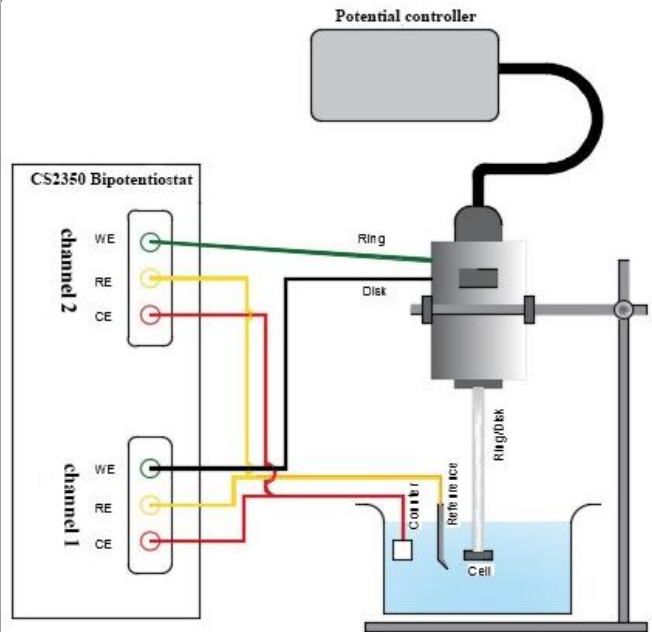
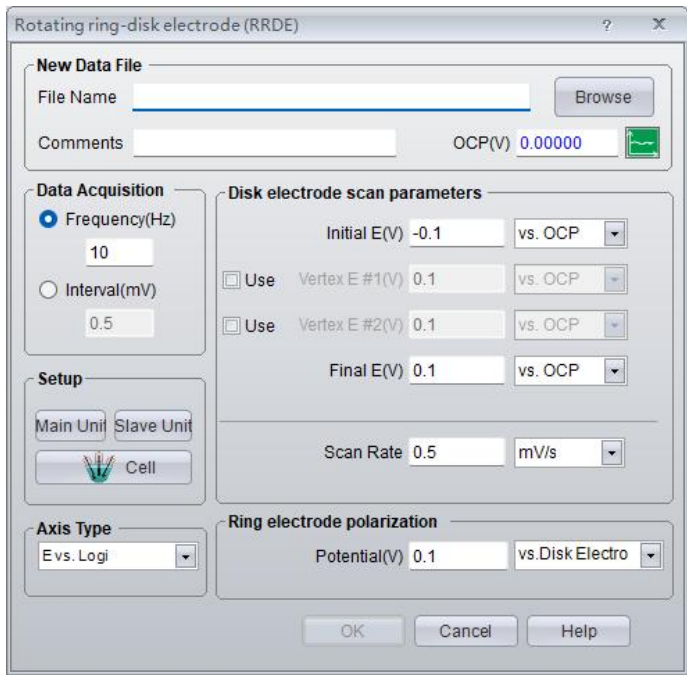

## Hydrogen Diffusion Test (HDT)

CS2150 bipotentiostat is combined with H-cells. By measuring current of cathode hydrogen charging and hydrogen atoms anode oxidation, it can further calculate the diffusion coefficient of hydrogen atoms in metal and hydrogen flux.

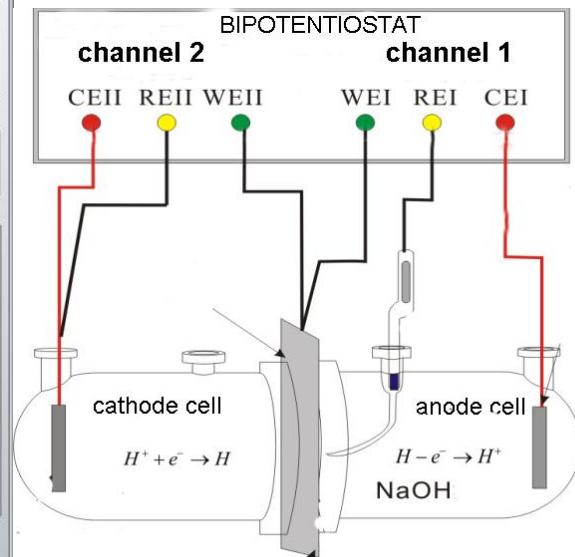
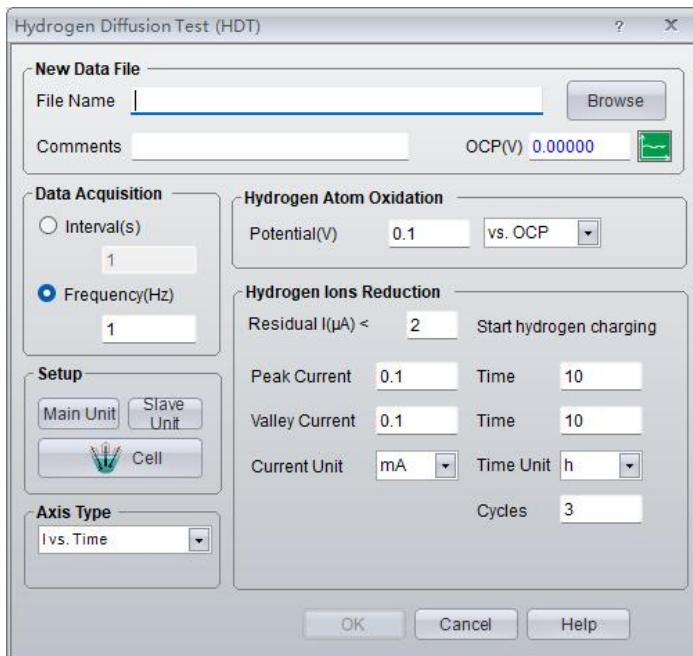

## Specifications

Specifications	
Support 2-, 3- or 4-electrode system	Interface: Ethernet
Potential control range: Primary Channel: $\pm 10V$ second Channel: $\pm 10V$	Current control range: $\pm 2A$
Potential control accuracy: $0.1\% \times \text{full range} \pm 1mV$	Current control accuracy: $0.1\% \times \text{full range}$
Potential resolution: $10\mu V$ ( $>100Hz$ ), $3\mu V$ ( $<10Hz$ )	Current sensitivity: $1pA$
Rise time: $<1\mu S$ ( $<10mA$ ), $<10\mu S$ ( $<2A$ )	Reference electrode input impedance: $1012\Omega$   $20pF$
Current range: $2nA \sim 2A$ , 10 ranges	Compliance voltage: $\pm 21V$
Maximum current output: $\pm 2A$	CV and LSV scan rate: $0.001mV \sim 10,000V/s$
CA and CC pulse width: $0.0001 \sim 65,000s$	Current increment during scan: $1mA @ 1A/ms$
Potential increment during scan: $0.076mV @ 1V/ms$	SWV frequency: $0.001 \sim 100 kHz$
DPV and NPV pulse width: $0.0001 \sim 1000s$	AD data acquisition: $16bit @ 1 MHz, 20bit @ 1 kHz$
DA Resolution: $16bit$ , setup time: $1\mu s$	Minimum potential increment in CV: $0.075mV$
IMP frequency: $10\mu Hz \sim 1MHz$	Low-pass filters: Covering 8-decade
Potential and current range: Automatic	Weight / Measurements: $8kg, 36.5 \times 30.5 \times 16cm$
Operating System: Windows 2000/NT/XP/ win7/win8/win10	
Electrochemical Impedance Spectroscopy (EIS)	
Signal generator	
Frequency range: $10\mu Hz \sim 1MHz$	AC amplitude: $1mV \sim 2500mV$
DC Bias: $-10 \sim +10V$	Output impedance: $50\Omega$
Waveform: sine wave, triangular wave and square wave	Wave distortion: $<1\%$
Scanning mode: logarithmic/linear, increase/decrease	
Signal analyzer	
Integral time: minimum: $10ms$ or the longest time of a cycle	Maximum: $10^6$ cycles or $10^5s$
Measurement delay: $0 \sim 10^5s$	
DC offset compensation	
Potential automatic compensation range: $-10V \sim +10V$	Current compensation range: $-1A \sim +1A$
Bandwidth: 8-decade frequency range, automatic and manual setting	

## Techniques/Methods in each channel - CS2350M

### Stable polarization

- Open Circuit Potential (OCP)
- Potentiostatic (I-T curve)
- Galvanostatic
- Potentiodynamic (Tafel plot)
- Galvanodynamic (DGP)
- Sweep-Step Functions (SSF)

### **Transient Polarization**

- Multi Potential Steps
- Multi Current Steps
- Potential Stair-Step (VSTEP)
- Galvanic Stair-Step (ISTEP)

### **Chrono Method**

- Chronopotentiometry (CP)
- Chronoamperometry (CA)
- Chronocoulometry (CC)

### **Voltammetry**

- Linear Sweep Voltammetry (LSV)
- Cyclic Voltammetry (CV)
- Staircase Voltammetry (SCV)
- Square Wave Voltammetry (SWV)
- Differential Pulse Voltammetry (DPV)
- Normal Pulse Voltammetry (NPV)#
- Differential Normal Pulse Voltammetry (DNPV)
- AC Voltammetry (ACV)
- 2nd harmonic AC Voltammetry (SHACV)
- Fourier Transform AC Voltammetry (FTACV)

### **Amperometric**

- Differential Pulse Amperometry (DPA)
- Double Differential Pulse Amperometry (DDPA)
- Triple Pulse Amperometry (TPA)
- Integrated Pulse Amperometric Detection (IPAD)

### **Stripping Voltammetry**

- Potentiostatic Stripping
- Linear Stripping
- Staircase Stripping
- Square Wave Stripping
- Differential Pulse Voltammetry Stripping
- Normal Pulse Voltammetry Stripping
- Differential Normal Pulse Voltammetry Stripping

### **Electrochemical Impedance Spectroscopy (EIS)**

- EIS vs Frequency (IMP)
- Galvanostatic EIS
- EIS vs Potential (IMPE)(Mott-Schottky)
- EIS vs Time (IMPT)
- Galvanostatic EIS vs Time

### **Corrosion Measurements**

- Cyclic polarization curve (CPP)
- Linear polarization curve (LPR)
- Electrochemical Potentiokinetic Reactivation (EPR)
- Electrochemical Noise (EN)
- Zero resistance Ammeter (ZRA)

### **Battery test**

- Battery Charge and Discharge

- Galvanostatic Charge and Discharge (GCD)
- Potentiostatic Charging and Discharging
- Potentiostatic Intermittent Titration Technique
- Galvanostatic Intermittent Titration Technique

**Extensions**

- Data Logger
- Electrochemical Stripping/ Deposition
- Bulk Electrolysis with Coulometry (BE)
- Rs Measurement

## Technical advantages

### 1. Impedance (EIS)

CS2350M bipotentiostat applies correlation integral algorithm and dual-channel over-sampling technique, and has strong anti-interference ability. It is suitable for EIS measurements of high-impedance system ( $>10^9\Omega$ , such as coating, concrete etc.).

[EIS of AA6063 Al alloy in  \$Ce^{3+}\$  containing 3% NaCl solution](#)

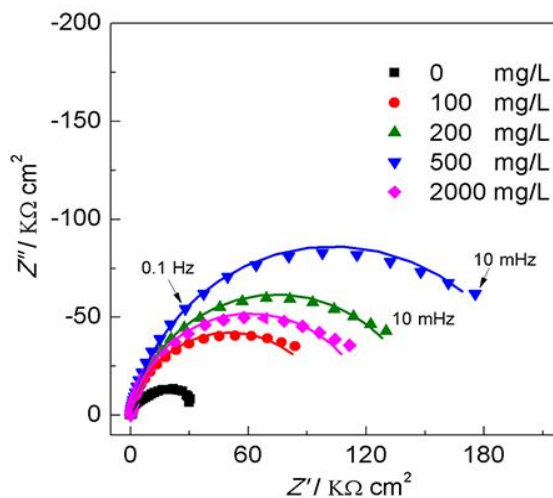

### 2. Polarization curve

Tafel plot can be obtained. The user can set the anodic reversal current (passivation film breakdown current) of the cyclic polarization curve to obtain material's pitting potential and protection potential and evaluate the its susceptibility to intergranular corrosion. The software uses non-linear fitting to analyze polarization curve, and can make fast evaluation of material's anti-corrosion ability and inhibitors.

[Polarization curve of Ti-based amorphous alloy & stainless steel in 3%NaCl solution](#)

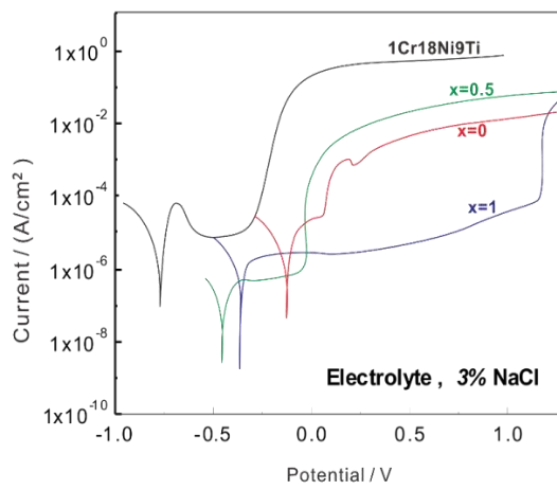

### 3. Voltammetry

Linear Sweep Voltammetry (LSV), Cyclic Voltammetry (CV), SCV, SWV, DPV, NPV, ACV, Stripping voltammetry etc. It integrates calculation of peak area, peak current and standard curve analysis.

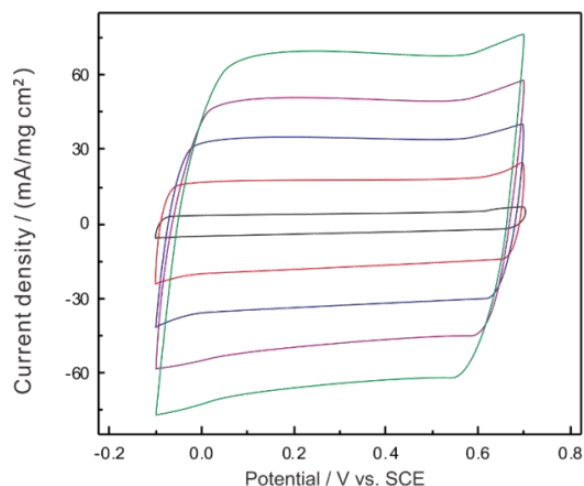
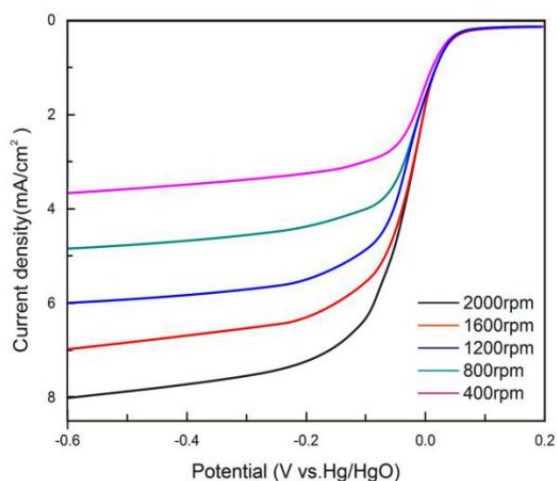

LSV: mesoporous carbon material in 0.1M KOH

CV of P

#### 4. Electrochemical Noise

With high-resistance follower and zero-resistance ammeter, it measures the natural potential/current fluctuations in corrosion system. It can be used to study pitting corrosion, galvanic corrosion, crevice corrosion, and stress corrosion cracking etc. Based on calculation of noise resistance and pitting index, it can complete localized corrosion monitoring.

#### 5. Full floating measurement

Full-floating mode be used for autoclave electrochemical measurements, on-line corrosion monitoring of metallic components under the ground (rebar in concrete, etc.)

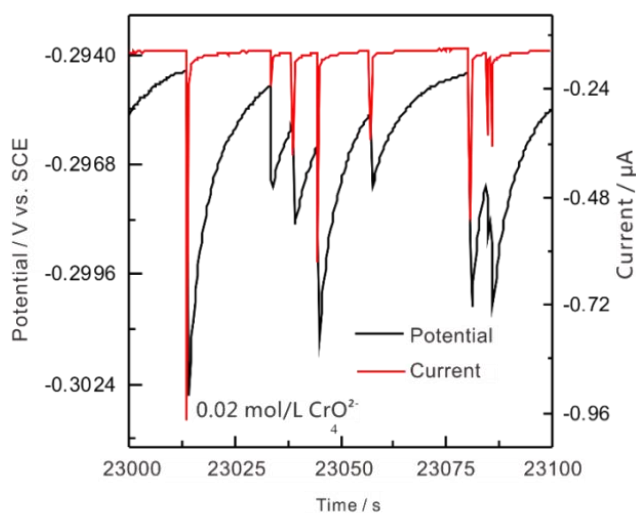

#### 6. Software development kit (SDK)

We are able to provide API functions and development examples, which facilitates some users' requirements for secondary development and self-defined measurements. We can provide .dll file.

### Software Features

**Cyclic voltammetry:** CS studio software provides users a versatile smoothing/differential/ integration kit, which can complete the calculation of peak height, peak area and peak potential of CV curves. During the data analysis, there is function of selecting exact cycle(s) to show. You can choose to see a cycle or some cycles as you want. You can also export data or vector graph of an exact cycle or several cycles.

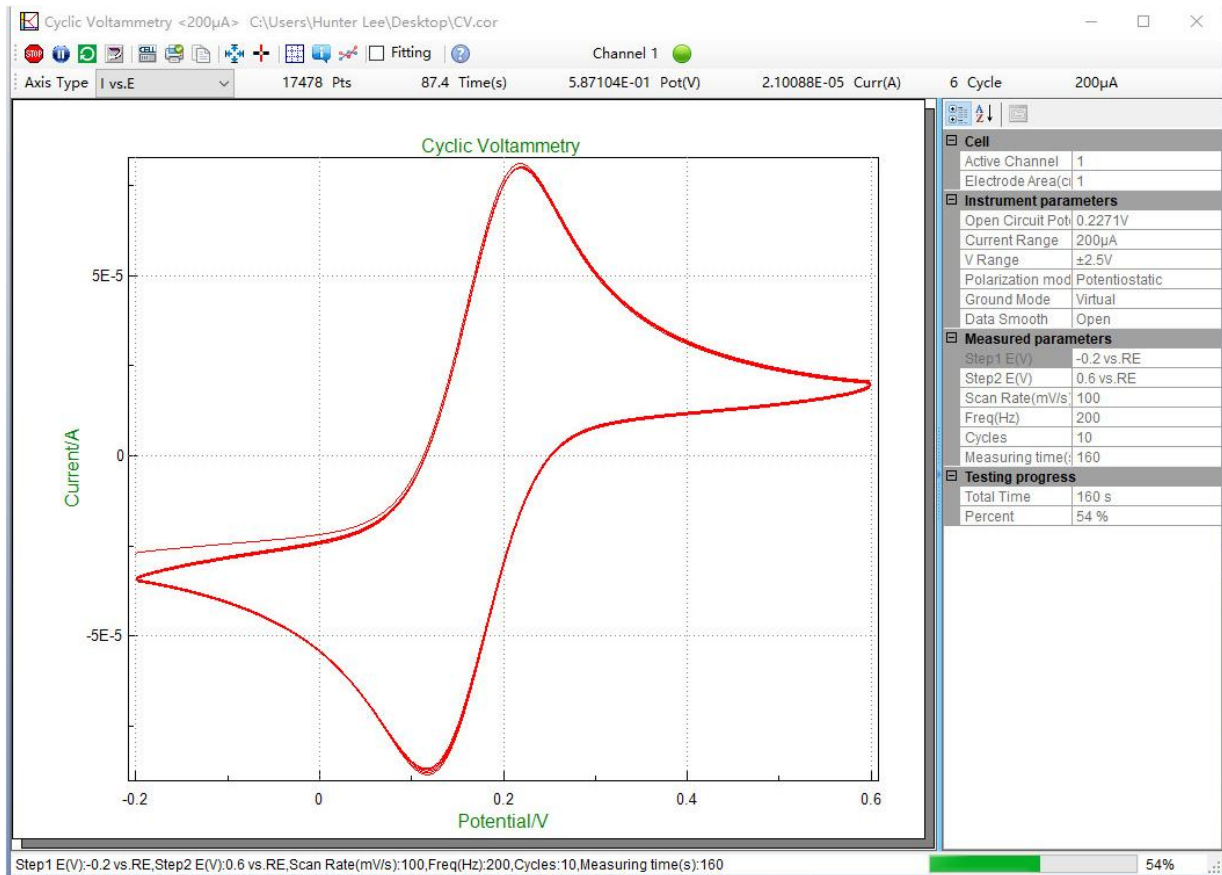

### Tafel plot and corrosion rate:

CS studio also provides powerful non-linear fitting on Butler-Volmer equation of polarization curve. It can calculate Tafel slope, corrosion current density, limitation current, polarization resistance, corrosion rate. It can also calculate the power spectrum density, noise resistance and noise spectrum resistance based on the electrochemical noise measurements.

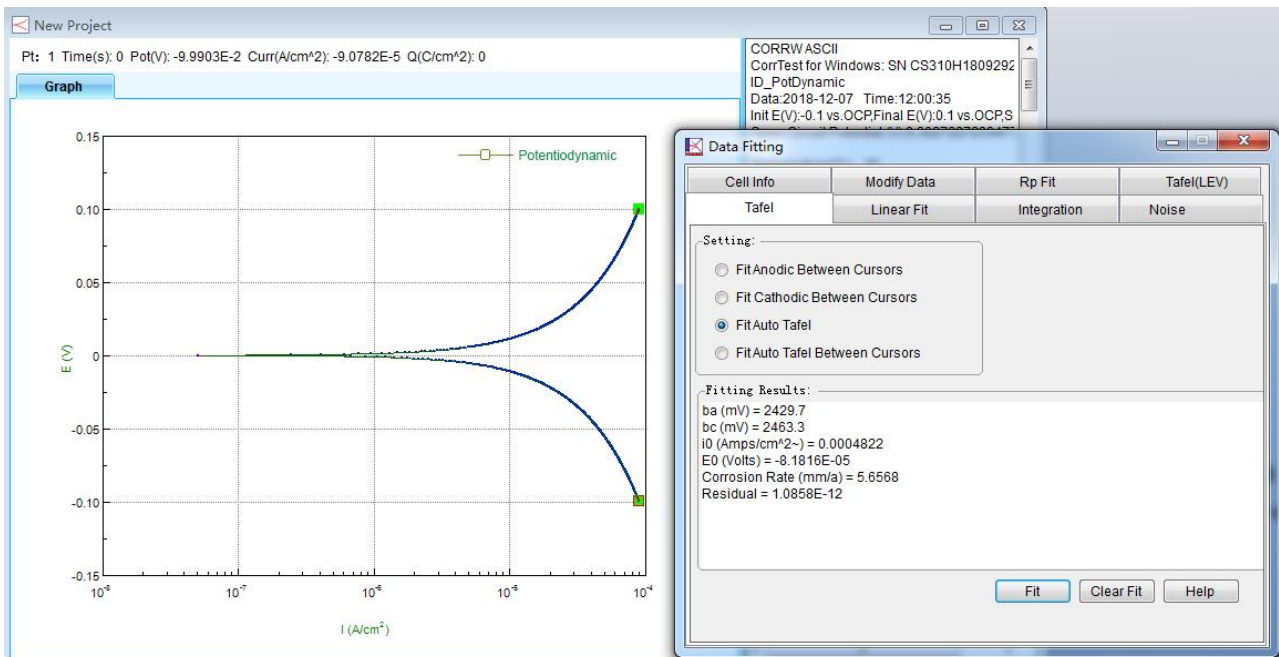

### Battery Test and analysis:

charge & discharge efficiency, capacity, specific capacitance, charge & discharge energy.

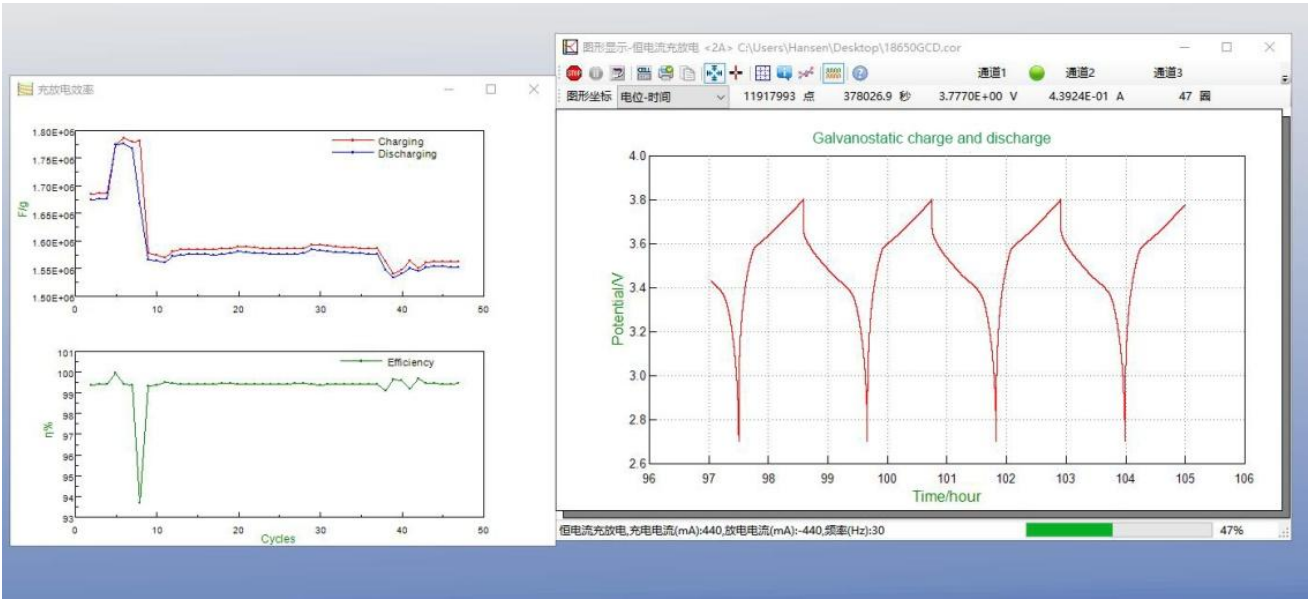

**EIS analysis:** Bode, Nyquist, Mott-Schottky plot

During EIS data analysis, there is built-in fitting function to draw the custom equivalent circuit.

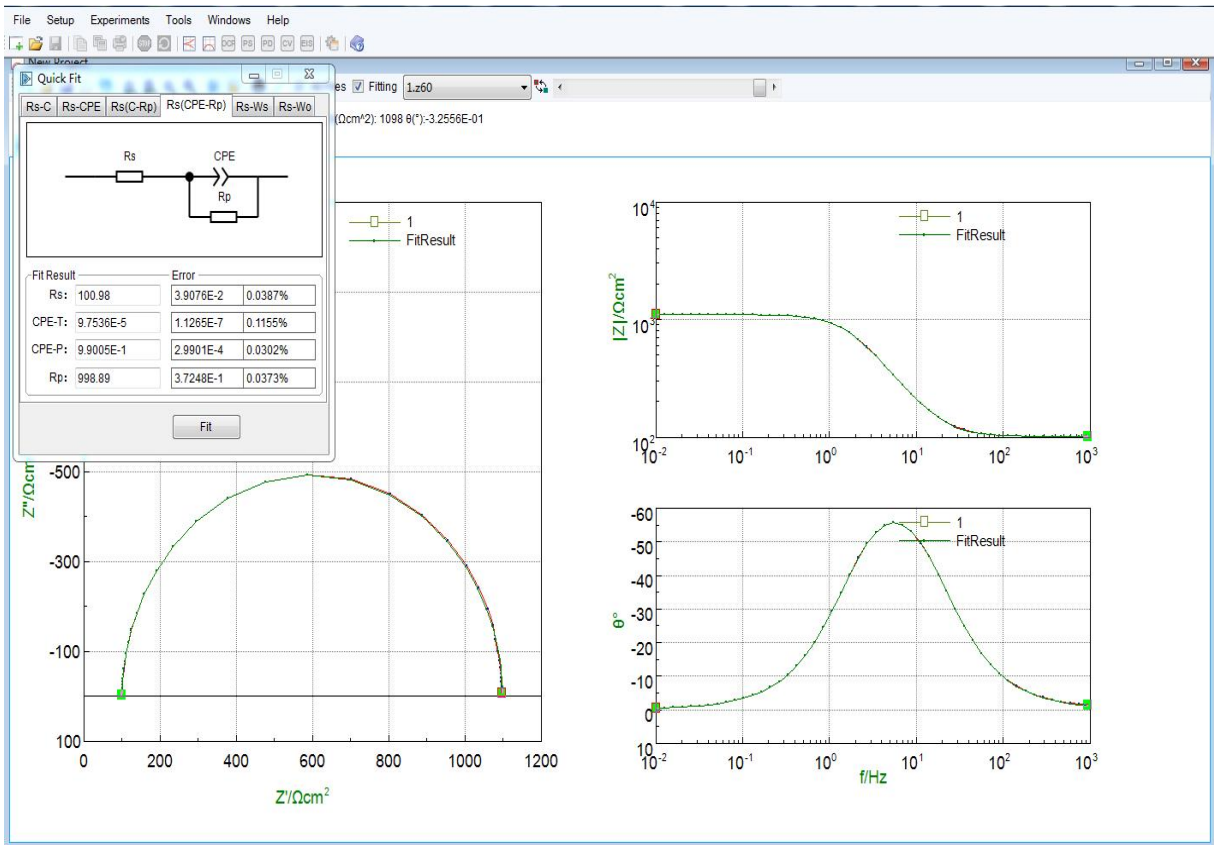

**Real time saving of data:** The data can be automatically saved even in case of sudden power off.

**Combination test:** it can achieve automation of experiments and save time. With the unique function of combination test, you can choose several experiments you want to run. Then you can make auto run of the pre-set experiments as you want without having to wait in the lab. This function is especially useful if you have multi experiments to run and save your time greatly.



No.	Name	Description	File
1	Start the cycle	Cycles:10	
2	Open Circuit Pot...	Freq(Hz):5, Hold Time(s):200	C:\Users\Administrat
3	Wait	After 60 seconds, testing will be continued	
4	EIS vs Frequency	DC Potential(V):0, Amplitude(mV):10, Initial Frequency:100000, Final Frequency:0....	C:\Users\Administrat
5	Wait	After 60 seconds, testing will be continued	
6	Potentiodynamic	Init E(V):-0.1 vsOCP, Final E(V):0.1 vsOCP, Scan Rate(mV/s):0.5, Freq(Hz):1	C:\Users\Administrat
7	End the cycle	End	

**Data open:** You can open the data files by txt format in notepad. Data can also be opened in Origin

### EIS BiPotentiostat / BiGalvanostat (2-channel) model CS2350M

#### Standard supply Include:

- Instrument **CS2350M** x1
- CS studio software x1
- Power cable x1,
- Ethernet cable x1,
- Cell cable x 4
- Dummy cell (1kΩ||100μF) x2

#### After-sales Service (\*\*All the after service is FREE)

1. Warranty period: 5 years.
2. Provide installation guide, manual, software installation video, and training videos.
3. Lifetime free software upgrading of the same model and technical service.
4. **Free** repair service

#### Contact us

##### Wuhan Corrttest Instruments Corp., Ltd.

Add: #505, Jinfeng Bld. A, International Enterprise Center,  
Optics valley Ave., East lake High-tech Dev. Zone, Wuhan city, 430074, China

Email: sales2@corrtest.com.cn

Mob./whatsapp: (+86)13469965984

Website: <https://www.corrtestinstruments.com/en> <http://www.corrtest.com.cn/en>